

**EN-GJS-400-18-LT (GGG-40.3), PN 16/25, with 8-15kN actuator**

**Body:** EN-GJS-400-18-LT (GGG-40.3), two way form for water and steam

Pressure range: PN 16, PN 25

Immersion length acc. to DIN EN 558, basic series 1

Flanges acc. to DIN EN 1092-2 type 21

Spindle sealing: spring-loaded PTFE-V-ring unit for media temperatures up to 250°C

Alternatively: graphite-packing

for media temperatures up to 350°C

Internal parts: stainless steel, replaceable seat rings

Flow characteristic: equal percentage

Positioning ratio: 50:1

Leakage: < 0,01% Kvs

**Actuator:** with manual emergency operation and load dependent limit switches

Thrust: 8 kN / 34 VA (appendix ...e)

12 kN / 34 VA (appendix ...f)

15 kN / 50 VA (appendix ...h)

Power supply: 230V / 50Hz

Alternatively: 230V / 60Hz(appendix...e6/f6/h6)

Other voltages: 115V 50/60Hz, 24V 50/60Hz,

24V DC, 400V 3Ph. on request

Motor rating standard acc. to DIN EN 60034-1: S4-30%ED - 600c/h

Protection class acc. to DIN EN 60529: IP65

**Accessories, special types:**

Add. limit switches load dependent

Add. signal switches travel dependent

Feedback potentiometer

Integrated positioner

Feedback signal 4-20mA / 0-10V

Actuator heater (on request)

Other positioning speed (on request)

Other Kvs- values (on request)

Weld-on ends (on request)

Flange drillings acc. to ANSI / JIS (on request)

**Order text:**

Motor control valve in two way form

EN-GJS-400-18-LT (GGG-40.3), PN . . , DN . . , Kvs . . .

Spindle sealing with PTFE-V-ring unit

Power supply . . . , closing pressure . . . bar

List-No. 421 . . . H . . , accessories . . .

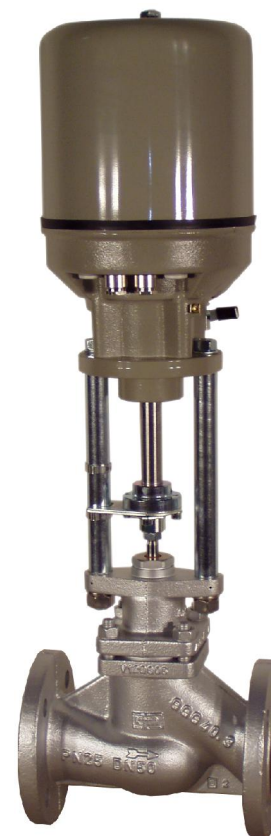

**Pressure-temperature ratings acc. to DIN EN 1092-2:**

by:	-10...120	150	200	250	300	350	°C*
PN 16	16	15,5	14,7	13,9	12,8	11,2	bar
PN 25	25	24,3	23	21,8	20	17,5	bar

\* = max. 250°C for spindle sealing with PTFE-V-ring unit

DN	List-No.		Kvs m³/h	Stroke mm	Pos. time sec	Closing pressure* (bar)		
	PN 16	PN 25				8kN(...e)	12kN(...f)	15kN(...h)
50	421 405H.	421 505H.	40	20	48	25,0		
65	421 406H.	421 506H.	63	30	72	20,4	25,0	
80	421 408H.	421 508H.	100	30	72	13,4	21,0	
100	421 410H.	421 510H.	160	30	72	8,4	13,3	
125	421 412H.	421 512H.	230	60	90	5,2	8,4	10,8
150	421 415H.	421 515H.	330	60	90	3,5	5,7	7,4

\* higher closing pressure and bigger DN on request

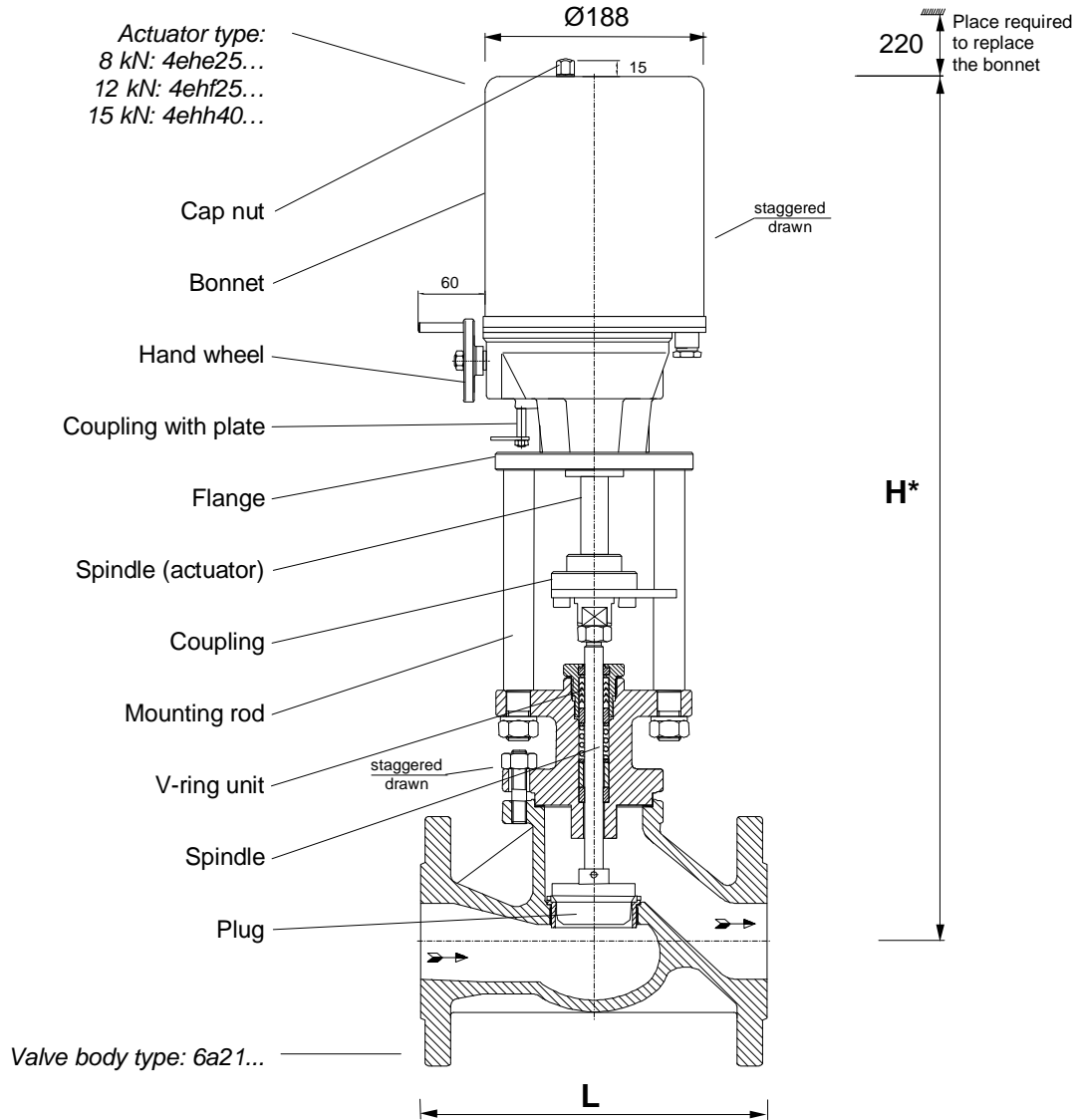

DN	50	65	80	100	125	150
Height H*	625	668	669	676	834	849
Length L	230	290	310	350	400	480
Weight kg	25	39	42	52	104	114

\* = add. 20mm for 15kN actuator

**Electrical wiring 230/115/24 V 50/60 Hz:\*\***

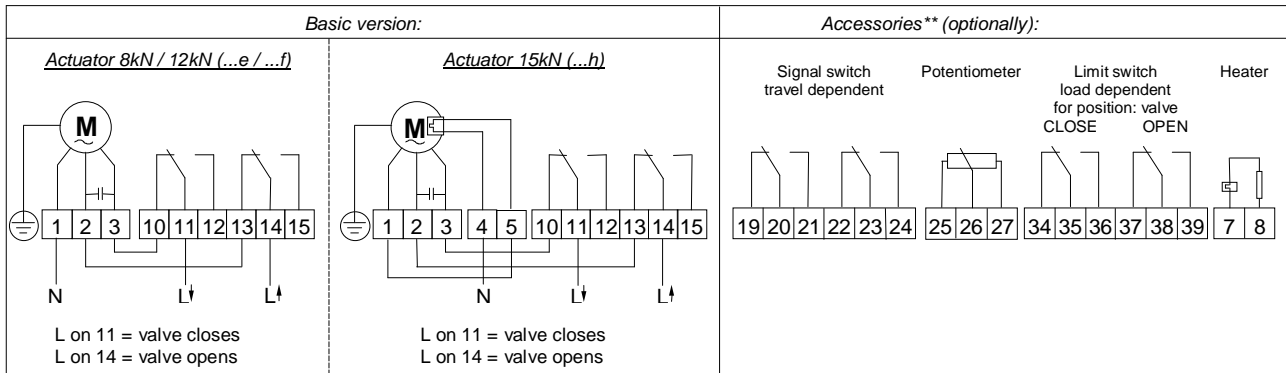

\*\* = for other voltages / accessories see wiring diagrams in operating instruction 4eh80\_b.