

Body: GP240GH+N (GS-C25N), two way form
for heat transfer oil
Pressure range: body PN 40
 bellow PN 25
Immersion length acc. to DIN EN 558, basic series 1
Flanges acc. to DIN EN 1092-1 type 21
Spindle sealing: double wall bellow
and safety stuffing box
Internal parts: stainless steel, replaceable seat rings
Flow characteristic: equal percentage
Positioning ratio: 30:1
Leakage: < 0,01% Kvs

Actuator: with manual emergency operation
and load dependent limit switches
Thrust: 2000 N
Power input: 12 VA
Alternatively: 4000 N / 28 VA (appendix ...c)
 5500 N / 28 VA (appendix ...d)
Power supply: 230V/50...60Hz
Optionally: 115V/50...60Hz, 24V/50...60Hz, 24VDC
Motor rating standard acc. to DIN EN 60034-1: S1 – 100%
Protection class acc. to DIN EN 60529: IP65

Accessories, special types:
Add. limit switches load dependent (see page 49e)
Add. signal switches travel dependent (see page 49w)
Feedback potentiometer (see page 49f)
Integrated positioner (see page 49sr)
Integrated process controller (see page 49r)
Feedback signal 4-20mA / 0-10V
Actuator heater (on request)
Other positioning speed (on request)
Other Kvs- values (on request)
Weld-on ends (on request)
Flange drillings acc. to ANSI / JIS (on request)



Order text:
Motor control valve in two way form
GP240GH+N (GS-C25N), body PN 40, DN . . . , Kvs . . .
Spindle sealing with bellow PN 25
Power supply . . . , closing pressure . . . bar
List-No. 451 6 . . . , accessories . . .

Pressure-temperature ratings:

by:	-10	200	250	300	350	400	°C
	25	25	25	25	24	21	bar

DN	List-No.	Kvs m³/h	Stroke mm	Pos. time sec	Closing pressure* (bar)		
					2000N	4000N	5500N
15	451 600	4	20	66	25,0		
20	451 601	6,3	20	66	25,0		
25	451 602	10	20	66	25,0		
32	451 603.	16	20	66	17,3	25,0	
40	451 604.	25	20	66	10,8	25,0	
50	451 605.	40	20	66	6,6	16,0	23,0
65	451 606.	63	30	100	3,4	9,1	13,3
80	451 608.	100	30	100	2,0	5,8	8,6
100	451 610.	160	30	100	1,1	3,5	5,4

* see page 4516He/f/h for higher closing pressure; bigger DN on request

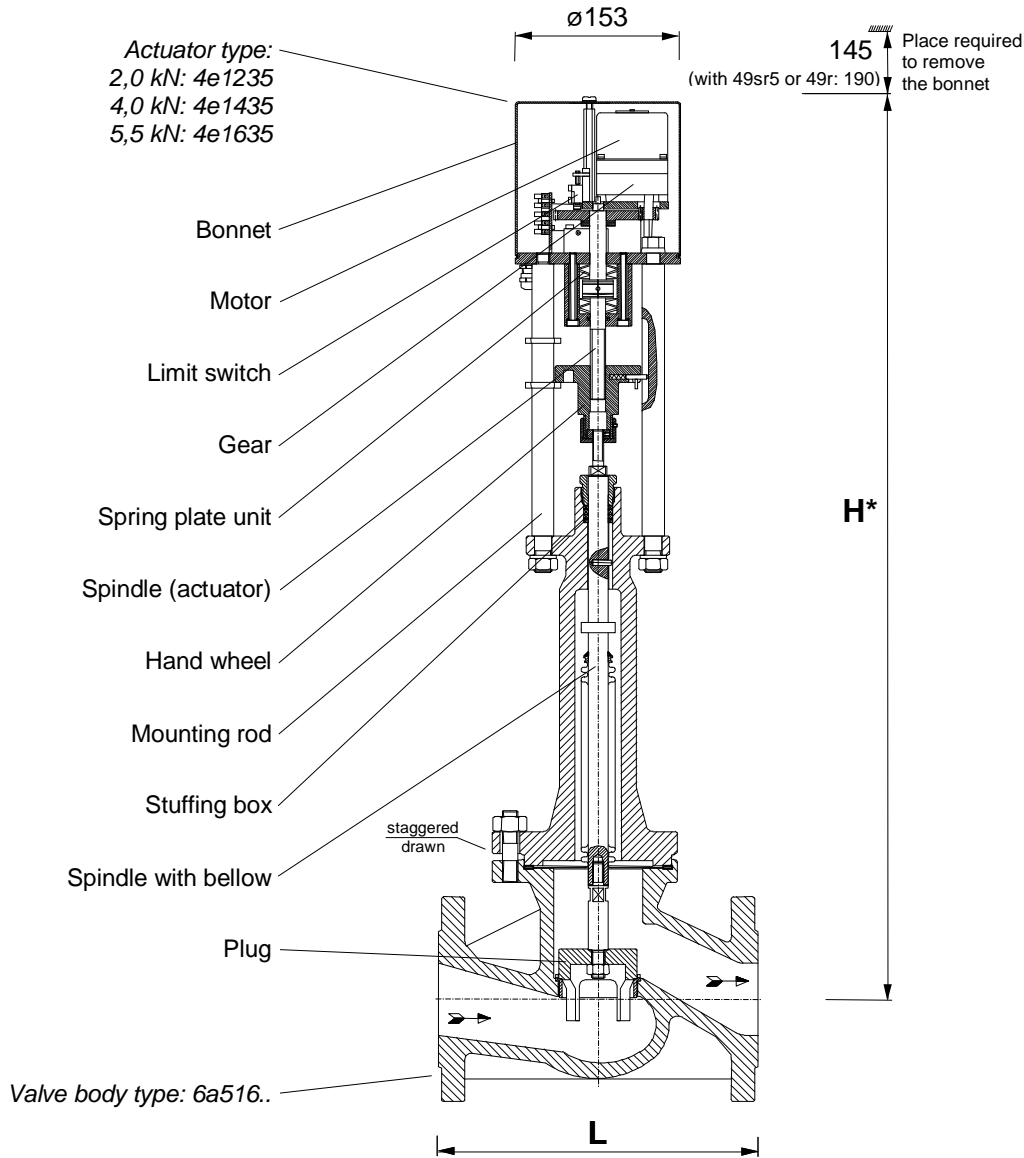

DN	15	20	25	32	40	50	65	80	100
Height H*	661	675	669	676	681	683	813	814	821
Length L	130	150	160	180	200	230	290	310	350
Weight kg	17	18	19	20	22	24	43	47	57

* = add. 45mm for actuators with positioner 49sr5 or controller 49r

Electrical wiring:

