

Gate Valve Outside Screw



PN 63 DN 50 - DN 400

Flanges PN 63 or PN 40

Fig. 250-550

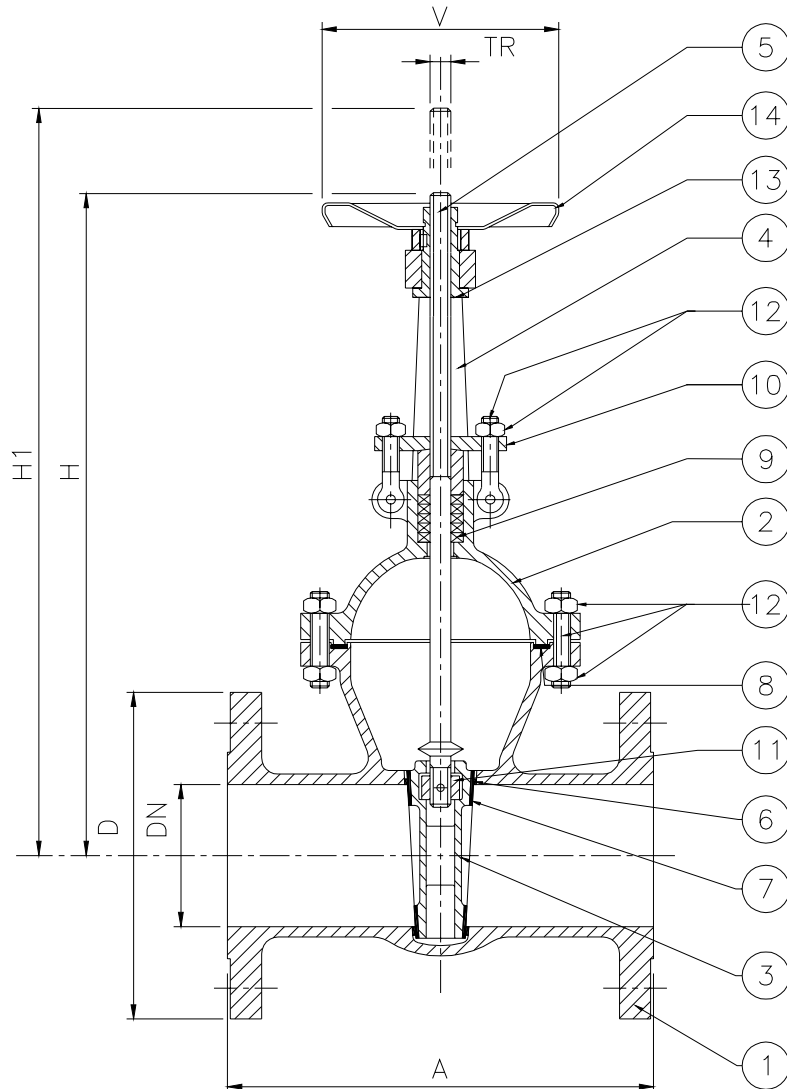

0948

Rel. 4.0

Standard features:

- Design EN 12516
EN 1984
- Face to face EN 558 series 26
- Flanges EN 1092-1/21/B2
- Materials EN 10213
EN 10269
EN 10088
- Bolts and nuts EN 1515-1
- Welding overlay AD-M HP 0
- Testing EN 1984
EN 12266
- Marking EN 19
- Certificates EN 10204

Optional versions:

- AD 2000 – A4
- TRD 110
- DIN 3230 Part 4
- DIN 3230 Part 5
- DIN 3230 Part 6
- TRbF 131
- TRbF 301
- TRbF 302
- TA-Luft
- With flanges PN 25 or PN 16
- With flanges form A, B2, C, D, E, F, G, H
- With butt welding ends (EN 12982 / EN 12627)
- With special devices (see pages 30 – 31)

	DESCRIPTION	FIG. 250	FIG. 350	FIG. 350-J	FIG. 450	FIG. 450-H	FIG. 550
1	Body	1.0619	1.4581	1.4308	1.7357	1.7379	1.1138
2	Bonnet	1.0619	1.4581	1.4308	1.7357	1.7379	1.1138
3	x Wedge	1.0619	1.4581	1.4308	1.7357	1.7379	1.1138
4	Yoke	1.0619	1.4581	1.4308	1.7357	1.7379	1.1138
5	x Stem	1.4021 ⁽¹⁾	1.4571 ⁽¹⁾	1.4301 ⁽¹⁾	1.4021 ⁽¹⁾	1.4021 ⁽¹⁾	1.4021 ⁽¹⁾
6	Body seats	1.4502 ⁽²⁾	1.4581 ⁽²⁾	1.4308 ⁽²⁾	1.4502 ⁽²⁾	Stellite	1.4502 ⁽²⁾
7	Wedge seats	1.4502 ⁽²⁾	1.4581 ⁽²⁾	1.4308 ⁽²⁾	1.4502 ⁽²⁾	Stellite	1.4502 ⁽²⁾
8	O Gasket	Graphite + SS ⁽³⁾	Graphite + SS ⁽³⁾	PTFE ⁽³⁾	Graphite + SS ⁽³⁾	Graphite + SS ⁽³⁾	Graphite + SS ⁽³⁾
9	O Packing	Graphite + SS ⁽³⁾	Graphite + SS ⁽³⁾	PTFE ⁽³⁾	Graphite + SS ⁽³⁾	Graphite + SS ⁽³⁾	Graphite + SS ⁽³⁾
10	x Gland	1.0402	1.4571	1.4301	1.0402	1.0402	1.4301
11	x Boss	1.4571	1.4571	1.4301	1.4571	1.4571	1.4571
12	Bolts	1.7225 ⁽⁴⁾	1.4301 ⁽⁴⁾	1.4301 ⁽⁴⁾	1.7711 ⁽⁴⁾	1.7711 ⁽⁴⁾	1.7225 ⁽⁴⁾
12	Nuts	1.1191 ⁽⁴⁾	1.4301 ⁽⁴⁾	1.4301 ⁽⁴⁾	1.7225 ⁽⁴⁾	1.7225 ⁽⁴⁾	1.7225 ⁽⁴⁾
13	x Yoke sleeve	1.0511 NHT	1.0511 NHT	1.0511 NHT	1.0511 NHT	1.0511 NHT	1.0511 NHT
14	x Handwheel	Pressed steel	Pressed steel	Pressed steel	Pressed steel	Pressed steel	Pressed steel

⁽¹⁾ Also available on request 1.4571, 1.4301, 1.3964, Hastelloy, or other materials.

⁽²⁾ Also available on request stellite, 1.4462 (duplex), 1.4430, 1.4316, Hastelloy, or other materials.

⁽³⁾ Also available on request PTFE, Gore-tex, graphite, or other materials and different desing (e.g. cam-profile).

⁽⁴⁾ Also available on request 1.7225 / 1.1191, 1.7711 / 1.7225, 1.4401, 1.4301, A4-70 or other materials.

O recommended spare parts for 2 years standard service; x recommended spare parts for 5 years standard service.

Dimensions

PN	63	DN	A	D	H	H1	TR	V	Kg	$\Delta p^{(5)}$	Wedge ⁽⁶⁾
		50	250	180	380	440	20 x 4	200	35	63	Split
65	290	205	455	530	22 x 5	200	44	63	Split		
80	310	215	465	545	22 x 5	250	48	63	Split		
100	350	250	490	600	22 x 5	250	57	63	Split		
125	400	295	615	750	24 x 5	250	81	63	Split		
150	450	345	695	860	28 x 5	300	125	63	Flexible		
200	550	415	845	1060	28 x 5	300	210	51	Flexible		
250	650	470	1000	1265	36 x 6	500	400	51	Flexible		
300	750	530	1140	1455	36 x 6	500	540	39	Flexible		
350	850	600	1250	1650	40 x 7	500	850	23	Flexible		
400	950	670	1430	1850	50 x 8	600	1120	15	Flexible		

⁽⁵⁾ Maximum differential pressure for manoeuvre without gear box or by-pass according to EN 12570 (if equal to 0 the gearbox is recommended).

⁽⁶⁾ Standard wedge type. Other execution available on request.

Pressure Temperature Ratings (°C / bar)

	PN	-195	-150	-100	-50	-10	0	20	100	150	200	250	300	350	400	425	450	475	500	525	550	575	600
Fig. 250	63				63,0	63,0	62,2	58,8	53,9	49,0	44,8	40,6	37,8	36,4	29,8	23,2							
Fig. 350 ⁽⁷⁾	63		63,0	63,0	63,0	63,0	60,8	51,8	48,3	44,8	42,7	40,6	38,5	36,4	35,7	35,0	34,3	33,6	32,9	32,2			
Fig. 350-J	63	63,0	63,0	63,0	63,0	63,0	59,4	44,8	39,9	35,0	32,9	30,8											
Fig. 450 ⁽⁷⁾ ⁽⁸⁾	63				63,0	63,0	63,0	63,0	63,0	63,0	63,0	63,0	60,2	56,0	54,6	53,2	43,0	32,8	24,1	15,4			
Fig. 450-H ⁽⁸⁾	63				63,0	63,0	63,0	63,0	63,0	63,0	63,0	63,0	63,0	63,0	63,0	62,0	61,0	49,6	38,1	28,3	18,5	13,2	7,8
Fig. 550	63				63,0	63,0	63,0	61,6	56,0	53,2	50,4	49,0	47,6										

Please, in the inquiry and in the order, specify always the maximum service temperature when it's over 100 °C.

If the valves are provided with flanged connection PN 40 the maximum allowable pressure should be proportionally reduced.

⁽⁷⁾ Suitable over 450 °C only if provided with stellite seats. ⁽⁸⁾ Suitable over 530 °C only if provided with 1.3964 stem.

General sale and delivery conditions and product guarantee as specified at pages 48 and 49.

Due to constant improvement all data and details contained in this catalogue are purely indicative and they can be subjected to change without notice.