



PowerTrap®

MODEL GT10 CAST IRON CAST STEEL

MECHANICAL PUMP WITH STEAM TRAP FOR CONDENSATE REMOVAL AND RECOVERY

Features

Pump/Trap with built-in steam trap for a wide range of applications: drainage of heat exchangers, flash steam recovery systems and non-vented receivers such as low-pressure stages of turbines and absorption chillers, often operating under vacuum conditions.

1. Handles high-temperature condensate without cavitation.
2. No electric power or additional level controls required, hence INTRINSICALLY SAFE.
3. Pump will operate with a low filling head.
4. Durable nickel-based alloy compression coil spring.
5. Easy, inline access to internal parts simplifies cleaning and reduces maintenance costs.
6. High-quality stainless steel internals and hardened working surfaces ensure reliability.

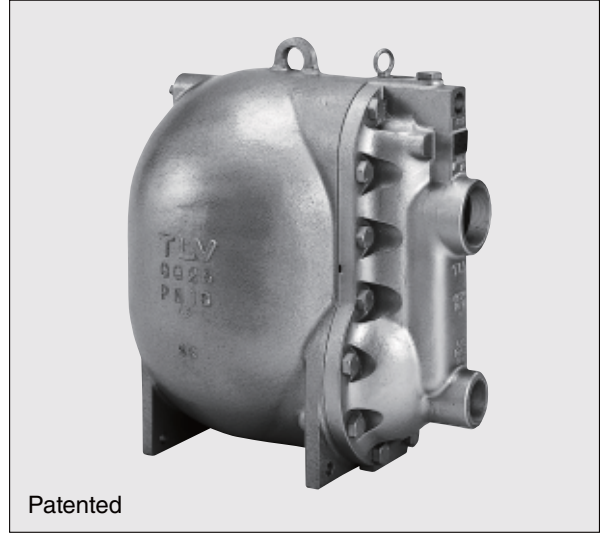

Specifications

Model		GT10		
Body Material		Cast Iron	Cast Steel	
Connection	Pumped Medium Inlet & Outlet	Screwed	Screwed	Flanged
	Motive Medium & Pump Exhaust	Screwed	Screwed	Flanged
Size (mm)	Pumped Medium Inlet x Outlet	3" x 2"		DN 50 x 50, 80 x 50
	Motive Medium Inlet	1"		DN 25
	Pump Exhaust Outlet	1"		DN 25
Maximum Operating Pressure (bar)	PMO	10.5		
Maximum Operating Temperature (°C)	TMO	185		
Motive Medium Pressure Range (bar)		0.3 – 10.5		
Maximum Allowable Back Pressure		0.5 bar less than motive medium pressure used		
Volume of Each Discharge Cycle (ℓ)		approximately 30		
Motive Medium*		Saturated Steam		
Pumped Medium**		Steam Condensate		

* Do not use with toxic, flammable or otherwise hazardous fluids.

** Do not use for fluids with specific gravities under 0.85 or over 1, or for toxic, flammable or otherwise hazardous fluids.

1 bar = 0.1 MPa

PRESSURE SHELL DESIGN CONDITIONS (NOT OPERATING CONDITIONS): Maximum Allowable Pressure (bar) PMA: 13 (Cast Iron), 16 (Cast Steel)
Maximum Allowable Temperature (°C) TMA: 200 (Cast Iron) 220 (Cast Steel)



To avoid abnormal operation, accidents or serious injury, DO NOT use this product outside of the specification range. Local regulations may restrict the use of this product to below the conditions quoted.

No.	Description	Material	DIN*	ASTM/AISI*	
①	Body	Cast Iron FC250	0.6025	A126 Cl.B	
		Cast Steel** A216 Gr.WCB	1.0619	—	
②	Cover	Cast Iron FC250	0.6025	A126 Cl.B	
		Cast Steel** A216 Gr.WCB	1.0619	—	
③	Cover Gasket	Graphite Compound	—	—	
④	Float	Stainless Steel SUS316L/303	1.4404/1.4305	AISI316L/303	
⑤	Lever Unit	Stainless Steel	—	—	
⑥	Snap-action Unit	Stainless Steel	—	—	
⑦	Motive Medium Intake Valve Unit	Intake Valve	Stainless Steel SUS303/440C	1.4305/1.4125	AISI303/440C
		Valve Seat	Cast Stainless Steel A351 Gr.CF8/ Stainless Steel SUS440C	1.4312/ 1.4125	—/ AISI440C
⑧	Exhaust Valve Unit	Exhaust Valve	Stainless Steel SUS303/440C	1.4305/1.4125	AISI303/440C
		Valve Seat	Stainless Steel SUS420F	1.4028	AISI420F
⑨	Trap Unit	Stainless Steel	—	—	
⑩	Check Valve***	CK3MG	Cast Stainless Steel A351 Gr.CF8	1.4312	—
		CKF3MG	Cast Stainless Steel A351 Gr.CF8	1.4312	—

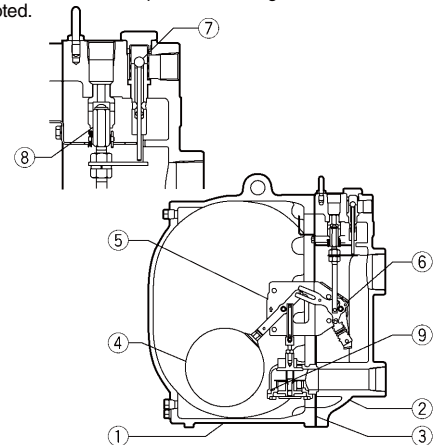

Copyright © TLV

* Equivalent materials ** Option: Cast Stainless Steel

*** Not shown, model depends on GT10 connection; CK3MG for screwed, CKF3MG for flanged

Discharge Capacity

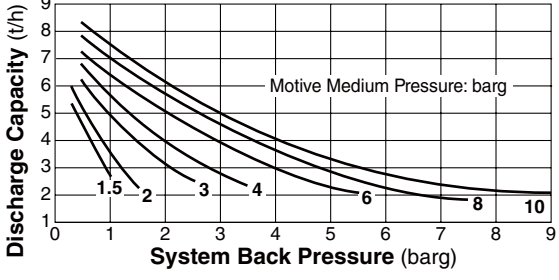
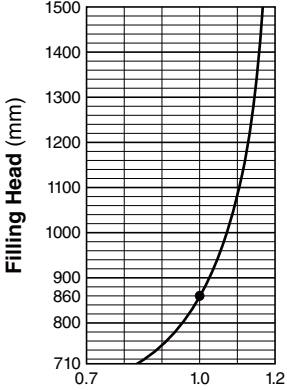
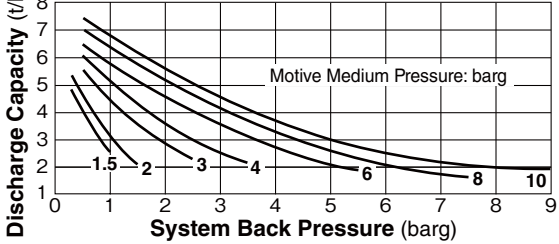
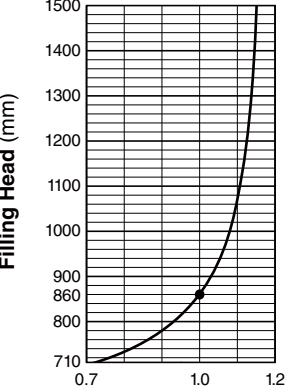
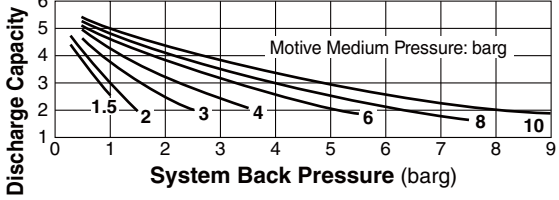
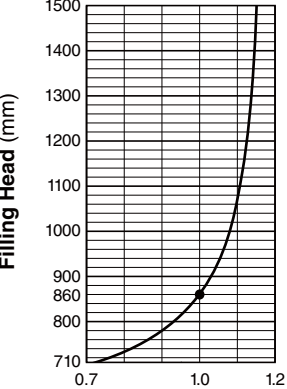
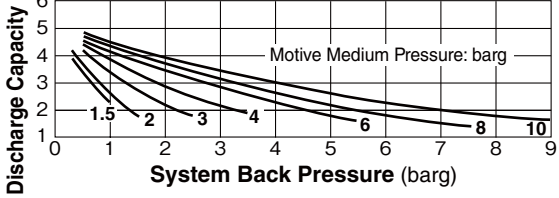
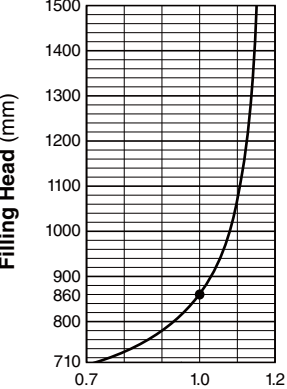
Check Valve Size & Model	Motive Medium: Saturated Steam Condensate Temperature: 90 °C Filling Head: 860 mm (see correction factors for other filling heads)	Correction Factors (for filling heads other than 860 mm)
3" Inlet / 2" Outlet CK3MG	<p>A</p> 	 <p>(minimum filling head: 710 mm)</p>
DN 80 Inlet / DN 50 Outlet CKF3MG	<p>B</p> 	 <p>(minimum filling head: 710 mm)</p>
2" Inlet / 2" Outlet CK3MG	<p>C</p> 	 <p>(minimum filling head: 710 mm)</p>
DN 50 Inlet / DN 50 Outlet CKF3MG	<p>D</p> 	 <p>(minimum filling head: 710 mm)</p>

1 bar = 0.1 MPa

NOTE:

- A check valve must be installed at both the pumped medium inlet and outlet. To achieve the above capacities with the standard GT10 configuration, TLV CK3MG or CKF3MG check valves must be used.
- Motive medium pressure minus back pressure must be greater than 0.5 bar.
- A strainer must be installed at the motive medium and pumped medium inlets.

• Illustration of Filling Head and Pressures

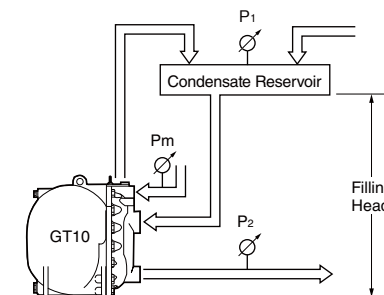

The discharge capacity is determined by the motive medium, motive medium pressure (Pm) and back pressure (P2).

Make sure that:
Discharge Capacity × Correction Factor > Required Flow Rate

Dimensions

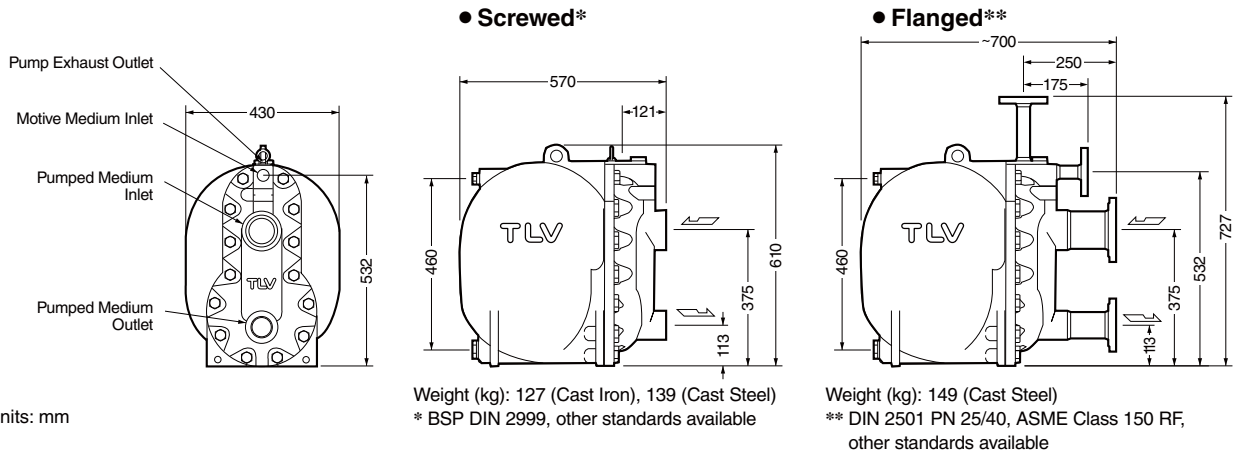

Units: mm

Size of Reservoir

The reservoir must have a capacity sufficient to store the condensate produced during the **PowerTrap** operation and discharge.

Size of Reservoir (flash steam is not involved)

Amount of Condensate (kg/h)	Reservoir Diameter (mm) and Length (m)						
	40	50	80	100	150	200	250
300 or less	1.2m	0.7					
400	1.5	1.0					
500	2.0	1.2	0.5				
600		1.5	0.6				
800		2.0	0.8	0.5			
1000			1.0	0.7			
1500			1.5	1.0			
2000			2.0	1.3	0.6		
3000				2.0	0.9	0.5	
4000					1.2	0.7	
5000					1.4	0.8	0.5
6000					1.7	1.0	0.6
7000					2.0	1.2	0.7
8000						1.3	0.8
9000						1.5	0.9
10000						1.7	1.0

Reservoir length can be reduced by 50% when the motive medium pressure (Pm) divided by back pressure (P2) equals 2 or greater (when $P_m \div P_2 \geq 2$).

Steam Consumption (Motive Medium)

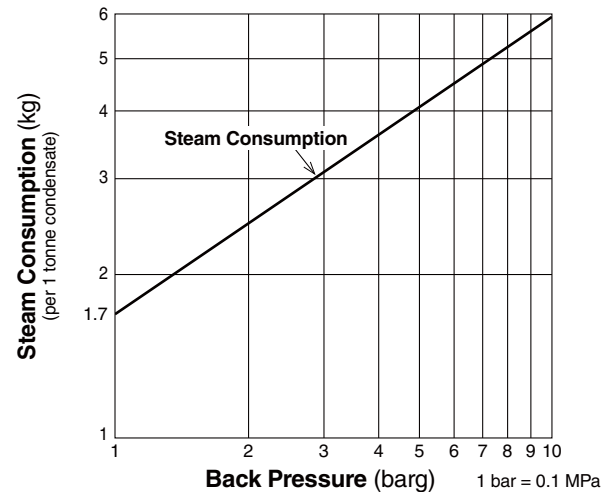

GT10 Steam Trap Discharge Capacity

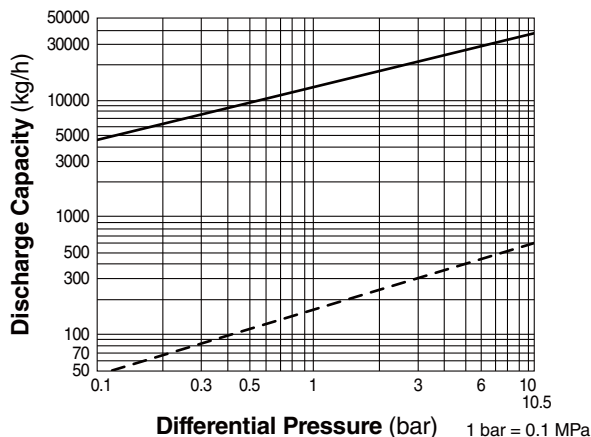

— : Capacity of GT10 as a steam trap ($P_1 > P_2$).
Instantaneous condensate loads above the rated trap capacity will cause the pump to cycle and therefore reduce the discharge capacity.

- - - : Minimum amount of condensate required to prevent steam leakage.

1. Capacities are based on continuous discharge of condensate 6 °C below steam temperature.
2. Differential pressure is the difference between inlet and outlet pressure of the trap.



DO NOT use this product under conditions that exceed maximum differential pressure, as condensate backup will occur!

Memo:

Manufacturer

ISO 9001/ISO 14001

TLV® CO., LTD.
Kakogawa, Japan

is approved by LRQA Ltd. to ISO 9001/14001

