

Motor Valve 8037

ex-version

GS 1 series, DN 15 up to DN 150

SCHUBERT & SALZER
**CONTROL
SYSTEMS**

Motor valve for control and switching of neutral through to highly aggressive media in process engineering, chemical industries and for plant equipment, for applications in Ex-Zone 1, 2, 21 and 22.

Technical Information Valve

Design	flangeless, wafer type construction Dimensions acc. DIN EN 558-1 series 20 for flanges acc. DIN EN 1092-1 form B more versions see data sheet 8037-GS3		
Nominal size	DN 15 up to DN 150		
Nominal pressure	PN 40 acc. DIN 2401 also for flanges PN10 up to PN25		
Media temperature	body 1.0570: -10°C up to +300°C body: 1.4571: -60°C up to +350°C (+300°C für SFC)		
Rangeability	30 : 1		
Leakage (% of Kvs)	Disc pair Carbon-stainless steel < 0,0001	Disc pair SFC < 0,0005	Disc pair STN 2 < 0,001

Kvs-values see data sheet 8001.



 **TÜVRheinland®**
TA-Luft zertifiziert

Technical Information Actuator

Driving force	1 kN , 2,5 kN , 5 kN
Stroking speed	2 / 3 / 6 / 9 / 12 s/mm (adjustable)
Power supply	24 ... 230 V AC/DC (longer range power supply)
Input signal	3-point 4 - 20 mA or 0 - 10 V
Feedback	4 - 20 mA or 0 - 10 V
Explosion protection (gas)	II 2G Ex de [ia] IIC T6/T5
Explosion protection (dust)	II 2D Ex tD [iaD] A21 IP66 T80°C
Protection class	IP 66
Ambient temperature	-20...+40°C at T6 / -20...+50°C at T5
Operating mode	S3 / 50% ED (max. 600 switching cycle / h)
Hysteresis	ca. ±1,5%
Resolution	ca. 100 steps
Ambient temperature	self-learning
Heating resistor element	16 Watt self actuating
Motor	brushless DC motor
Manual override	hexagon key (top of header)

Stroking times for the complete stroke (sec.):

Speed [s/mm]	2	3	6	9	12
DN 15 - 40	12,5	18,8	37,5	56,3	75,0
DN 50 - 80	16,5	24,8	49,5	74,3	99,0
DN 100 - 200	17,5	26,3	52,5	78,8	105,0

= factory setting

Admissible Differential Pressures

DN	1,0 kN			2,5 kN			5,0 kN		
	max. differential pressure (bar)								
	carbon/SFC - stainless steel coated								
15	40	40	40	40	40	40	40	40	40
20	40	40	40	40	40	40	40	40	40
25	40	40	40	40	40	40	40	40	40
32	40	40	40	40	40	40	40	40	40
40	40	40	40	40	40	40	40	40	40
50	26	40	40	40	40	40	40	40	40
65	22	40	40	40	40	40	40	40	40
80	14	37	40	40	40	40	40	40	40
100	9	23	23	23	23	23	23	23	23
125	6	16	16	16	16	16	16	16	16
150	4,5	12	12	12	12	12	12	12	12

DN	1,0 kN			2,5 kN			5,0 kN		
	max. differential pressure (bar)								
	STN2								
15	40	40	40	40	40	40	40	40	40
20	40	40	40	40	40	40	40	40	40
25	36	40	40	40	40	40	40	40	40
32	26	40	40	40	40	40	40	40	40
40	18	27	27	27	27	27	27	27	27
50	11	29	40	40	40	40	40	40	40
65	9	24	37	37	37	37	37	37	37
80	5	14	22	22	22	22	22	22	22
100	3	9	13	13	13	13	13	13	13
125	2	6	8,5	8,5	8,5	8,5	8,5	8,5	8,5
150	1,5	4,5	9	9	9	9	9	9	9

Options

- 2 potential-free limit switches at a separated terminal box
- inductive proximity switches (mounted at the column)
- Version only for zone 2 and zone 22
- Version not ex-actuator

Applications limits for GS1-Valves made of stainless steel

PN 40

DN	Sliding unit: carbon/SFC - stainless steel, coated					
	max. admissible pressures for GS1-valves					
	100°C	150°C	200°C	250°C	300°C	350°C
15 - 25	40	38	34	33	31	29
32	40	38	34	33	31	29
40	40	38	34	33	31	29
50	40	38	34	33	31	29
65	40	38	34	33	31	29
80	40	38	34	31	26	23
100	24	23	22	19	16	14
125	16	15	14	12	10	9,0
150	16	15	14	13	12	12

DN	Sliding unit: carbon - STN2					
	max. admissible pressures for GS1-valves					
	100°C	150°C	200°C	250°C	300°C	350°C
15 - 25	40	38	34	33	31	29
32	40	38	34	31	25	22
40	27	25	24	19	16	14
50	40	38	34	33	28	24
65	37	35	33	27	22	19
80	22	21	20	16	13	11
100	13	12	12	10	8,0	7,0
125	8,8	8,4	8,0	6,5	5,3	4,6
150	11	10	9,8	7,9	6,5	5,6

Limitation for valves in carbon steel and SFC-sliding discs: 300°C

ex-version

Ordering Number System

pos. 1 up to 4 please quote
 pos. 5 to 13 quote only if required.
 from pos. 14 if required, quoted by the manufacturer

Ordering Number:	1	2	3	4	5	6	7	8	9	10	11	12	13	14
8037/			H			M							Z	...
Nominal Size														
e.g. DN 25 = 025	xxx													
Article														
valve			V											
lower part			U											
repair-kit			R											
Function														
ex-proofed motor actuator (Type 8037)			H											
Body design														
flangeless design for flanges acc. DIN2632-2635 (PN10-PN40)				0										
Body material														
carbon steel 1.0570 / 1.0619				0										
stainless steel 1.4571 / 1.4581				1										
Safety position														
without safety position				0										
Motor actuator														
without actuator					0									
1 kN driving force, on /off, 3-point, IP65, 24...230V AC/DC, II 2GEx de [ia] IIC T5/T6					1									
2,5 kN driving force, on /off, 3-point, IP65, 24...230V AC/DC, II 2GEx de [ia] IIC T5/T6					2									
5 kN driving force, on /off, 3-point, IP65, 24...230V AC/DC, II 2GEx de [ia] IIC T5/T6					3									
1 kN driving force with electronic positioner, IP65, 24...230V AC/DC, control signal 4-20mA/0-10V, feedback 4-20 mA/0-10V, II2G Ex de [ia] IIC T5/T6						A								
2,5 kN driving force with electronic positioner, IP65, 24...230V AC/DC, control signal 4-20mA/0-10V, feedback 4-20 mA/0-10V, II2G Ex de [ia] IIC T5/T6						B								
5 kN driving force with electronic positioner, IP65, 24...230V AC/DC, control signal 4-20mA/0-10V, feedback 4-20 mA/0-10V, II2G Ex de [ia] IIC T5/T6						C								
Motor voltage														
24...230V AC/DC (standard)							-							
Stem sealing														
standard (PTFE-V-shaped seal, self-adjusting)								-						
additional stainless steel bellows								1						
Sliding disc														
carbon steel									-					
STN2/STN3									g					
SFC									S					
Fixed disc														
standard coated, stainless steel 1.4571										-				
STN2										1				
STN3										2				
Kvs-value														
100% (standard)												-		
red. 63%												A		
red. 40%												1		
red. 25%												B		
red. 16%												2		
red. 10%												C		
further reductions on request (see data sheet 8001)												...		
Seat characteristics														
linear													-	
equal percentage													1	
Accessories														
please note if required														Z

On request further versions are possible!

Dimensions and Weights

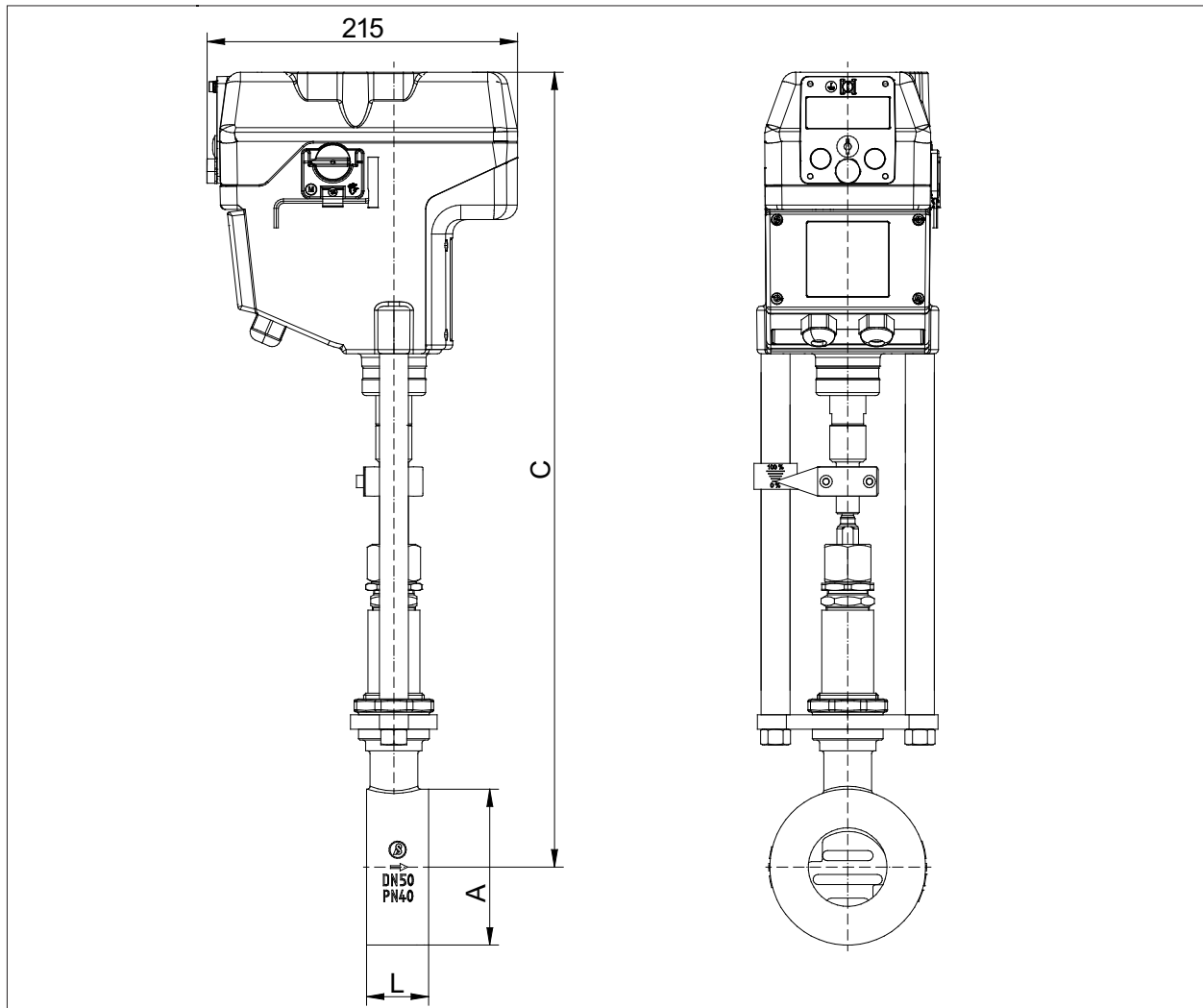

DN	A	C	L	Weight kg	Stroke
15	53	520	33	10,6	6
20	62	525	33	10,7	6
25	72	530	33	10,8	6
32	82	535	33	11,2	6
40	92	540	33	11,3	6
50	108	550	43	12,6	8
65	127	560	46	13,2	8
80	142	570	46	13,9	8
100	164	580	52	15,6	8,5
125	194	595	56	19,0	8,5
150	219	610	56	20,7	8,5

Dimensions in mm